

HXYx 4 axes / ZRL

● Arm type ● Cable carrier ● Z-axis: clamped base / moving table type (200W)+R-axis

Ordering method

| | | | | | | | | | | | | | |
|-------------|----------------------|-------------|---------------|---------------|------------|---------------|---|---------------|--|-------------------|---|---|-----------|
| HXYx | C | | | | ZRL | | | RCX240 | | R | | | BB |
| Model | Cable | Combination | X-axis stroke | Y-axis stroke | ZR-axis | Z-axis stroke | Cable length | Controller | Usable for CE | Regenerative unit | Option I/O ^{Note 1} | Network option | Battery |
| | A1 A2 A3 A4 | | 25 to 125cm | 25 to 65cm | | 25 to 55cm | 3L: 3.5m (Standard) 5L: 5m 10L: 10m | | No entry: Standard E: CE marking | R: RGU-2 | N.P. Standard I/O 16/8 N1, P1: 40/24 N2, P2: 64/40 N3, P3: 88/56 N4, P4: 112/72 | No entry: None CC: CC-Link DN: DeviceNet PB: Profibus EN: Ethernet YC: YC-Link ^{Note 2} | BB: 4 pcs |

Note 1. N to N4 if NPN was selected, or P to P4 if PNP was selected for the I/O board.
Note 2. Available only for the master.

Specification

| | X-axis | Y-axis | Z-axis | R-axis |
|--|-----------------------------|-----------------------|-----------------------|---------------|
| Axis construction ^{Note 1} | F20 | F17 | F14H-BK | R20 |
| AC servo motor output (W) | 600 | 400 | 200 | 200 |
| Repeatability ^{Note 2} (XYZ mm)(R °) | +/-0.01 | +/-0.01 | +/-0.01 | +/-0.0083 |
| Drive system | Ball screw (Class C7) | Ball screw (Class C7) | Ball screw (Class C7) | Harmonic gear |
| Ball screw lead (Deceleration ratio) (mm) | 20 | 20 | 10 | (1/50) |
| Maximum speed ^{Note 3} (XYZ mm/sec) (R °/sec) | 1200 | 1200 | 600 | 360 |
| Moving range (XYZ mm) (R °) | 250 to 1250 | 250 to 650 | 250 to 550 | 360 |
| Robot cable length (m) | Standard: 3.5 Option: 5, 10 | | | |

Note 1. Use caution that the flame machining (installation holes, tap holes) differs from single-axis robots.
Note 2. Positioning repeatability in one direction.
Note 3. When the X-axis stroke is longer than 850mm, resonance of the ball screw may occur depending on the operation conditions (critical speed). In this case, reduce the speed setting on the program by referring to the maximum speeds shown in the table below.

Maximum payload (kg)

| Y stroke (mm) | Z stroke (mm) | | | |
|---------------|---------------|-----|-----|-----|
| | 250 | 350 | 450 | 550 |
| 250 | 12 | 12 | 12 | 12 |
| 350 | 12 | 12 | 12 | 12 |
| 450 | 12 | 12 | 12 | 11 |
| 550 | 10 | 9 | 8 | 7 |
| 650 | 10 | 9 | 8 | 7 |

Controller

| Controller | Operation method |
|------------|--|
| RCX240-R | Programming / I/O point trace / Remote command / Operation using RS-232C communication |

HXYx 4 axes / ZRL (A1)

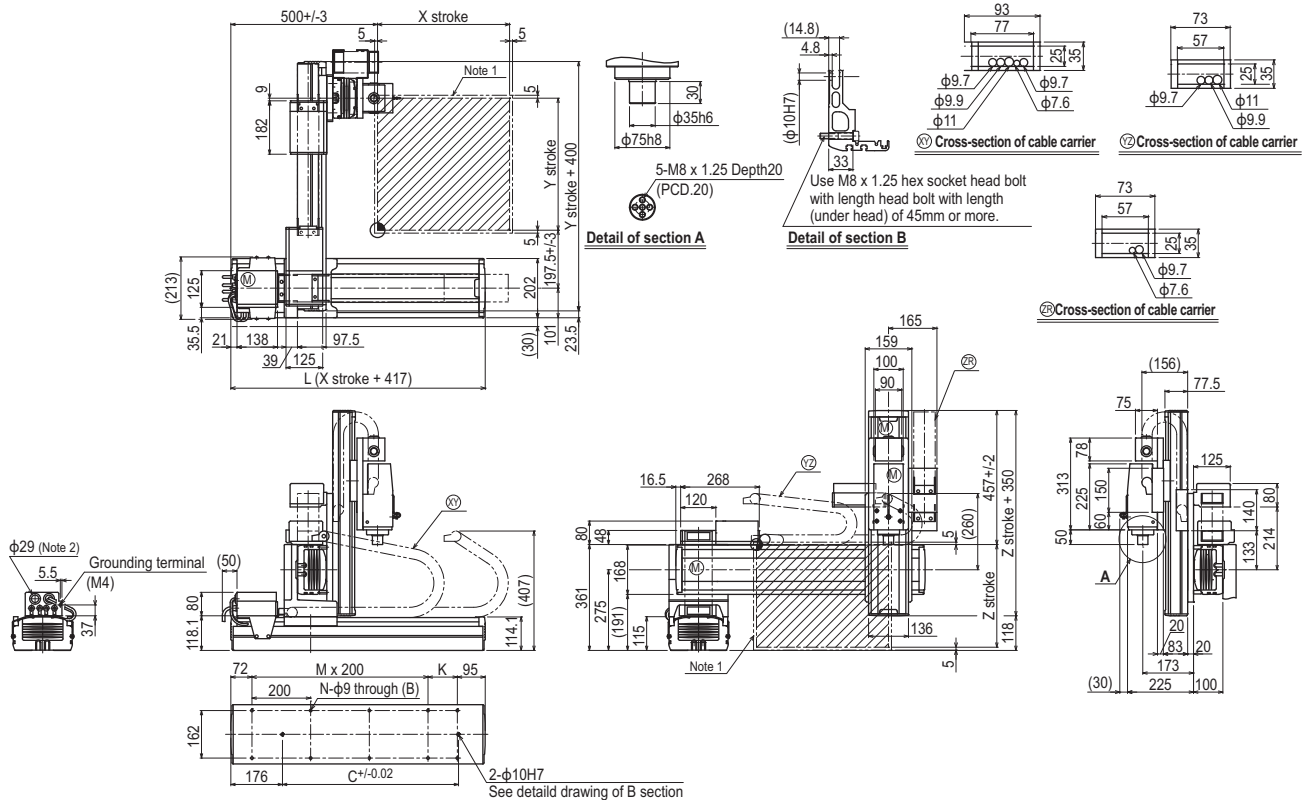

| X stroke | 250 | 350 | 450 | 550 | 650 | 750 | 850 | 950 | 1050 | 1150 | 1250 |
|--|--------|-----|------|-----|------|------|------|------|------|------|------|
| L | 667 | 767 | 867 | 967 | 1067 | 1167 | 1267 | 1367 | 1467 | 1567 | 1667 |
| K | 100 | 200 | 100 | 200 | 100 | 200 | 100 | 200 | 100 | 200 | 100 |
| C | 420 | 420 | 600 | 600 | 780 | 780 | 960 | 960 | 1140 | 1320 | 1320 |
| M | 2 | 2 | 3 | 3 | 4 | 4 | 5 | 5 | 6 | 6 | 7 |
| N | 8 | 8 | 10 | 10 | 12 | 12 | 14 | 14 | 16 | 16 | 18 |
| Y stroke | 250 | 350 | 450 | 550 | 650 | | | | | | |
| Z stroke | 250 | 350 | 450 | 550 | | | | | | | |
| Maximum speed for each stroke (mm/sec) ^{Note 1} | X-axis | | 1200 | | | | 960 | 840 | 720 | 600 | 480 |
| Speed setting | | | - | | | | 80% | 70% | 60% | 50% | 40% |

Note 1. The moving range when returning to origin and the stop position when stopping by the mechanical stopper.
Note 2. User cable extraction port.

Note 3. When the X-axis stroke is longer than 850mm, resonance of the ball screw may occur depending on the operation conditions (critical speed). In this case, reduce the speed setting on the program by referring to the maximum speeds shown in the table at the left.