

APPLICATION  
TRANSMISSION  
FLIP-X  
PHASER  
XY-X  
YK-XG  
YP-X  
CLEAN  
CONTROLLER INFORMATION  
Arm type  
Gantry type  
Moving arm  
Pole type  
XZ type

# NXY

## 3 axes / ZFH

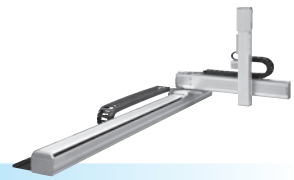

- Arm type
- Cable carrier
- Z-axis clamped table: moving base type (200W)

### Ordering method

**NXY - C** [ ] [ ] [ ] **ZFH** [ ] [ ] **RCX240** [ ] **R** [ ] [ ] **BB**

Model	Cable	Combination	X-axis stroke	Y-axis stroke	ZR-axis	Z-axis stroke	Cable length	Controller Note 1	Usable for CE	Regenerative unit	Option I/O Note 2	Network option	Battery
	A1 A3		50 to 200cm	15 to 65cm		15 to 35cm	3L: 3.5m (Standard) 5L: 5m 10L: 10m		No entry: Standard E: CE marking	R: RGU-2	N: P: Standard I/O 168 N1, P1: 40/24 N2, P2: 64/40 N3, P3: 88/56 N4, P4: 112/72	No entry: None CC: CC-Link DN: DeviceNet PB: Profibus EN: Ethernet YC: YC-Link	BB: 4 pcs

Note 1. Reference of special order: RCX222+SR1-X  
 Note 2. N to N4 if NPN was selected, or P to P4 if PNP was selected for the I/O board.  
 Note 3. Available only for the master.

### Specification

	X-axis	Y-axis	Z-axis
Axis construction Note 1	N15	F14	F10-BK equivalent guide-reinforced model
AC servo motor output (W)	400	100	200
Repeatability Note 2 (mm)	+/-0.01	+/-0.01	+/-0.01
Drive system	Ball screw (Class C7) φ15	Ball screw (Class C7) φ15	Ball screw (Class C7) φ15
Ball screw lead (Deceleration ratio) (mm)	20	20	10
Maximum speed (mm/sec)	1200	1200	600
Moving range (mm)	500 to 2000	150 to 650	150 to 350
Robot cable length (m)	Standard: 3.5 Option: 5, 10		

Note 1. Use caution that the flame machining (installation holes, tap holes) differs from single-axis robots.  
 Note 2. Positioning repeatability in one direction.

### Maximum payload (kg)

Y stroke (mm)	Z stroke (mm)		
	150	250	350
150	13	13	12
250	12	11	10
350	10	9	8
450	8	7	6
550	5	4	3
650	3	2	1

### Controller

Controller	Operation method
RCX240-R	Programming / I/O point trace / Remote command / Operation using RS-232C communication

### NXY 3 axes / ZFH (A1)

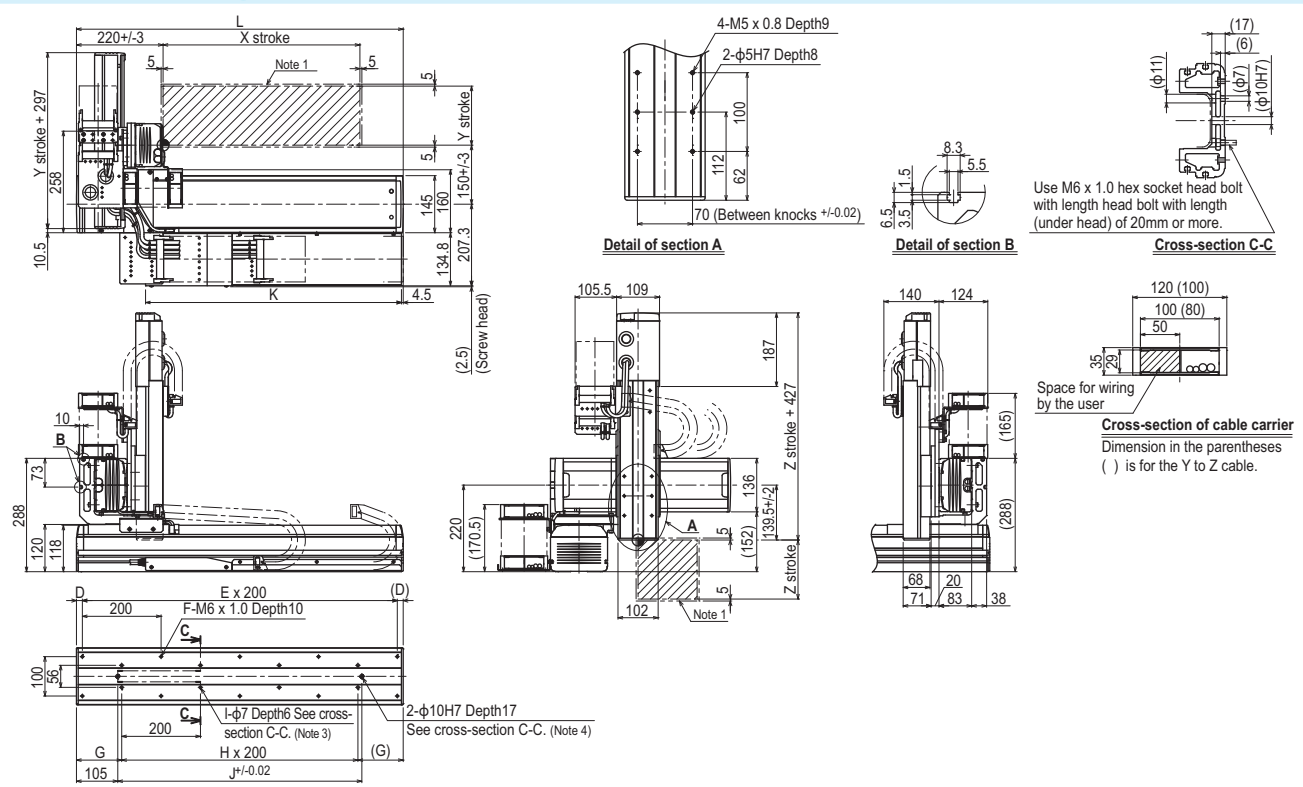

X stroke	500	600	700	800	900	1000	1100	1200	1300	1400	1500	1600	1700	1800	1900	2000
L	830	930	1030	1130	1230	1330	1430	1530	1630	1730	1830	1930	2030	2130	2230	2330
D	15	65	15	65	15	65	15	65	15	65	15	65	15	65	15	65
E	4	4	5	5	6	6	7	7	8	8	9	9	10	10	11	11
F	10	10	12	12	14	14	16	16	18	18	20	20	22	22	24	24
G	115	165	115	165	115	165	115	165	115	165	115	165	115	165	115	165
H	3	3	4	4	5	5	6	6	7	7	8	8	9	9	10	10
I	8	8	10	10	12	12	14	14	16	16	18	18	20	20	22	22
J	620	720	820	920	1020	1120	1220	1320	1420	1520	1620	1720	1820	1920	2020	2120
K	650	700	750	800	850	900	950	1000	1050	1100	1150	1200	1250	1300	1350	1400
Y stroke	150	250	350	450	550	650										
Z stroke	150	250	350													

Note 1. The moving range when returning to origin and the stop position when stopping by the mechanical stopper.  
 Note 2. The origin of the X axis is set originally as the drawing and it is possible to change it to the R side origin by changing parameters.  
 Note 3. When using φ7 holes for installation, you must not use a washer, spring washer, etc. in the main unit.  
 Note 4. When using a φ10H7 hole, make sure that the pin does not go into deeper than as shown in the drawing.  
 Note 5. Use M4 tap of the box next to X axis for the user grounding terminal.  
 Note 6. The M4 taps at both ends of the cable carriage can be used for fixing cables.

NXY 3 axes / ZFH **A3**

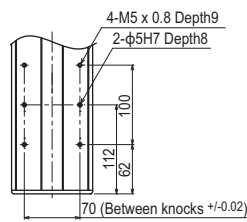

Detail of section A

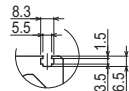

Detail of section B

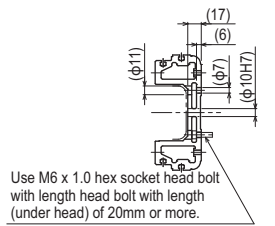

Cross-section C-C

Use M6 x 1.0 hex socket head bolt with length head bolt with length (under head) of 20mm or more.

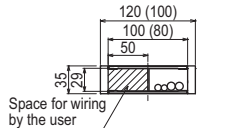

Cross-section of cable carrier  
 Dimension in the parentheses ( ) is for the Y to Z cable.

Space for wiring by the user

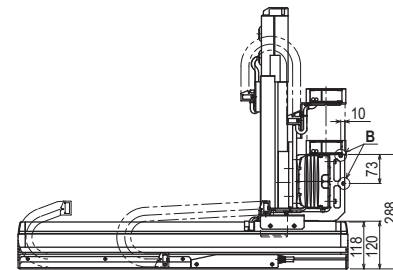
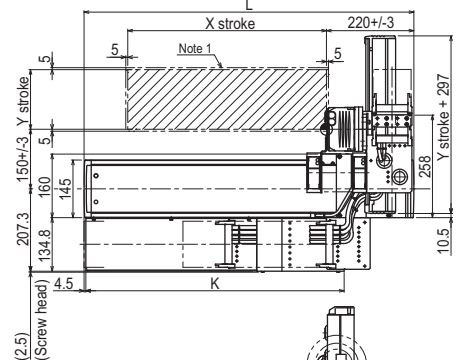
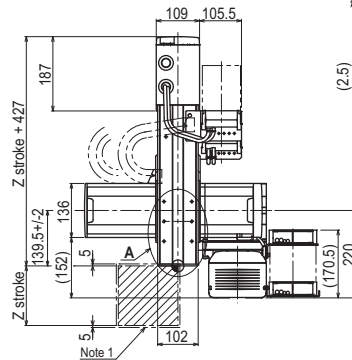
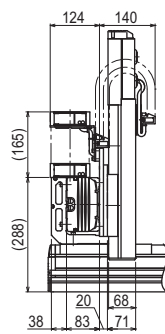

2-φ10H7 Depth17  
 See cross-section C-C. (Note 4)

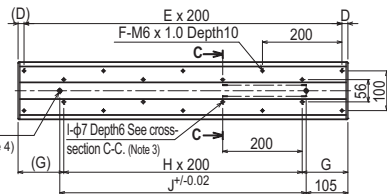

X stroke	500	600	700	800	900	1000	1100	1200	1300	1400	1500	1600	1700	1800	1900	2000
L	830	930	1030	1130	1230	1330	1430	1530	1630	1730	1830	1930	2030	2130	2230	2330
D	15	65	15	65	15	65	15	65	15	65	15	65	15	65	15	65
E	4	4	5	5	6	6	7	7	8	8	9	9	10	10	11	11
F	10	10	12	12	14	14	16	16	18	18	20	20	22	22	24	24
G	115	165	115	165	115	165	115	165	115	165	115	165	115	165	115	165
H	3	3	4	4	5	5	6	6	7	7	8	8	9	9	10	10
I	8	8	10	10	12	12	14	14	16	16	18	18	20	20	22	22
J	620	720	820	920	1020	1120	1220	1320	1420	1520	1620	1720	1820	1920	2020	2120
K	650	700	750	800	850	900	950	1000	1050	1100	1150	1200	1250	1300	1350	1400
Y stroke	150	250	350	450	550	650										
Z stroke	150	250	350													

- Note 1. The moving range when returning to origin and the stop position when stopping by the mechanical stopper.
- Note 2. The origin of the X axis is set originally as the drawing and it is possible to change it to the R side origin by changing parameters.
- Note 3. When using φ7 holes for installation, you must not use a washer, spring washer, etc. in the main unit.
- Note 4. When using a φ10H7 hole, make sure that the pin does not go into deeper than as shown in the drawing.
- Note 5. Use M4 tap of the box next to X axis for the user grounding terminal.
- Note 6. The M4 taps at both ends of the cable carriage can be used for fixing cables.